

B52 Channel & Combinations

B52

- Thickness: 12 Gauge (2.6 mm)
- Standard lengths: 10' (3.05 m) & 20' (6.09 m)
- Standard finishes: Plain, DURA GREEN™, Pre-Galvanized, Stainless Steel Type 304 or 316, Hot-Dipped Galvanized
- Weight: 1.27 Lbs./Ft. (1.89 kg/m)

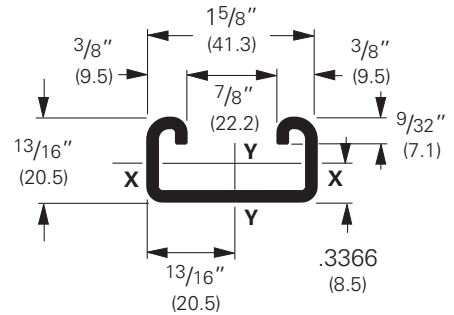
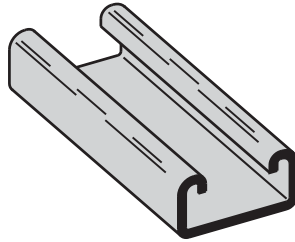

Section Properties

Channel	Weight lbs./ft. kg/m	Areas of Section sq. in. cm ²	X - X Axis			Y - Y Axis		
			Moment of Inertia (I) in. ⁴ cm ⁴	Section Modulus (S) in. ³ cm ³	Radius of Gyration (r) in. cm	Moment of Inertia (I) in. ⁴ cm ⁴	Section Modulus (S) in. ³ cm ³	Radius of Gyration (r) in. cm
B52	1.313 (1.95)	.386 (2.49)	.0320 (1.33)	.0673 (1.10)	.288 (.73)	.1404 (5.84)	.1728 (2.83)	.603 (1.53)
B52A	2.627 (3.91)	.773 (4.99)	.1517 (6.31)	.1868 (3.06)	.443 (1.13)	.2809 (11.69)	.3457 (5.67)	.603 (1.53)

Calculations of section properties are based on metal thicknesses as determined by the AISI Cold-Formed Steel Design Manual.

Channel & Combinations

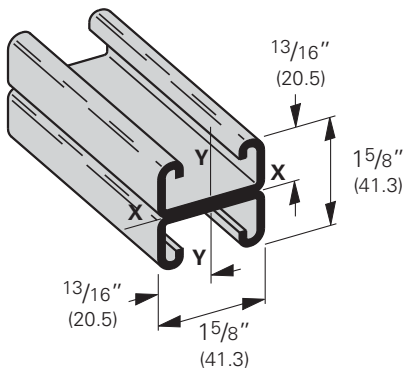

B52A

Wt. 2.54 Lbs./Ft. (3.78 kg/m)

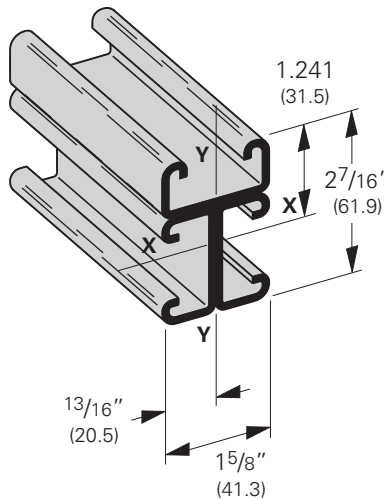

B52B3

Wt. 3.81 Lbs./Ft. (5.67 kg/m)

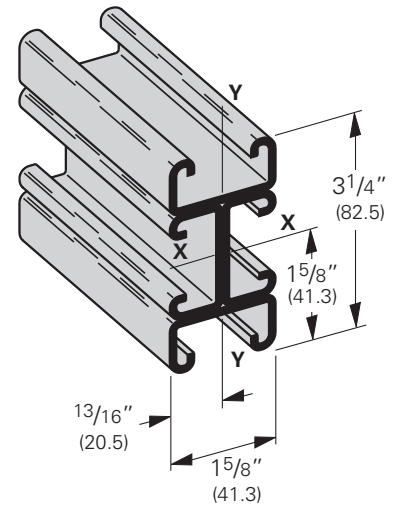

B52B4

Wt. 5.08 Lbs./Ft. (7.56 kg/m)

B52 Beam & Column Loading Data

Beam Loading

Beam Span In. mm	Channel Style	Uniform Load and Deflection				Uniform Load @ Deflection =			
		Lbs. kN		In. mm		1/240 Span Lbs. kN		1/360 Span Lbs. kN	
12 (305)	B52	1079	(4.80)	.026	(.66)	1079	(4.80)	1079	(4.80)
	B52A	1270*	(5.65)	.006	(.15)	1270*	(5.65)	1270*	(5.65)
24 (609)	B52	539	(2.40)	.106	(2.69)	506	(2.25)	337	(1.50)
	B52A	1270*	(5.65)	.052	(1.32)	1270*	(5.65)	1270*	(5.65)
36 (914)	B52	360	(1.60)	.240	(6.09)	225	(1.00)	150	(0.67)
	B52A	1013	(4.50)	.141	(3.58)	1013	(4.50)	719	(3.20)
48 (1219)	B52	270	(1.20)	.427	(10.84)	126	(0.56)	84	(0.37)
	B52A	759	(3.37)	.250	(6.35)	607	(2.70)	404	(1.80)
60 (1524)	B52	216	(0.96)	.667	(16.94)	81	(0.36)	54	(0.24)
	B52A	608	(2.70)	.391	(9.93)	388	(1.72)	259	(1.15)
72 (1829)	B52	180	(0.80)	.960	(24.38)	56	(0.25)	37	(0.16)
	B52A	506	(.225)	.563	(14.30)	270	(1.20)	180	(0.80)
84 (2133)	B52	154	(0.68)	1.307	(33.20)	41	(0.18)	28	(0.12)
	B52A	434	(1.93)	.766	(19.45)	198	(0.88)	132	(0.59)
96 (2438)	B52	135	(0.60)	1.707	(43.36)	32	(0.14)	21	(0.93)
	B52A	380	(1.69)	1.001	(25.42)	152	(0.67)	101	(0.45)
108 (2743)	B52	120	(0.53)	2.160	(54.86)	25	(0.11)	17	(0.75)
	B52A	338	(1.50)	1.267	(32.18)	120	(0.53)	80	(0.35)
120 (3048)	B52	108	(0.48)	2.667	(67.74)	20	(0.89)	13	(0.58)
	B52A	304	(.135)	1.564	(39.72)	97	(0.43)	65	(0.29)

Based on simple beam condition using an allowable design stress of 25,000 psi (172 MPa) in accordance with MFMA, with adequate lateral bracing (see page 12 for further explanation). Actual yield point of cold rolled steel is 42,000 psi. To determine concentrated load capacity at mid span, multiply uniform load by 0.5 and corresponding deflection by 0.8. *Failure determined by weld shear.

Column Loading

Unbraced Height In. mm	Channel Style	Max. Column Loading K = .80				Max. Column Loading (Loaded @ C.G.)					
		Loaded@ C.G.		Loaded@ Slot Face		K = .65		K = 1.0		K = 1.2	
		Lbs.	kN	Lbs.	kN	Lbs.	kN	Lbs.	kN	Lbs.	kN
12 (305)	B52	8407	(37.36)	3162	(14.06)	8543	(38.00)	8205	(36.50)	7989	(35.54)
	B52A	19160	(85.23)	5290	(23.53)	19425	(86.41)	18777	(83.52)	18363	(81.68)
24 (609)	B52	7519	(33.44)	2755	(12.25)	7879	(35.05)	6521	(29.01)	5397	(24.01)
	B52A	17444	(77.59)	4955	(22.04)	18144	(80.71)	16412	(73.00)	15275	(67.94)
36 (914)	B52	5397	(24.01)	2152	(9.57)	6653	(29.59)	3616	(16.08)	2511	(11.17)
	B52A	15275	(67.94)	4496	(20.00)	16547	(73.60)	13376	(59.50)	11243	(50.01)
48 (1219)	B52	3178	(14.13)	1560	(6.94)	4785	(21.28)	2034	(9.05)	1412**	(6.28)
	B52A	12692	(56.46)	3963	(17.63)	14667	(65.24)	9683	(43.07)	6780	(30.16)
60 (1524)	B52	2034	(9.05)	1159	(5.15)	3081	(13.70)	1302**	(5.79)	904**	(4.02)
	B52A	9683	(43.07)	3383	(15.05)	12516	(55.67)	6248	(27.79)	4339	(19.30)
72 (1829)	B52	1412**	(6.28)	891	(3.96)	2139	(9.51)	904**	(4.02)	-	-
	B52A	6780	(30.16)	2799	(12.45)	10084	(44.85)	4339	(19.30)	3013	(13.42)
84 (2133)	B52	1038**	(4.62)	704	(3.13)	1572	(6.99)	664**	(2.95)	-	-
	B52A	4981	(22.15)	2337	(10.39)	7545	(33.56)	3188	(14.18)	2214**	(9.85)
96 (2438)	B52	794**	(3.53)	570	(2.53)	1203**	(5.35)	-	-	-	-
	B52A	3814	(16.96)	1973	(8.77)	5777	(25.70)	2441**	(10.86)	1695**	(7.54)
108 (2743)	B52	-	-	470	(2.09)	951**	(4.23)	-	-	-	-
	B52A	3013	(13.40)	1684	(7.49)	4564	(20.30)	1928**	(8.57)	1339**	(5.95)
120 (3048)	B52	-	-	394	(1.75)	770**	(3.42)	-	-	-	-
	B52A	2441**	(10.86)	1452	(6.46)	3697	(16.44)	1562**	(6.95)	-	-

**Where the slenderness ratio $\frac{KL}{r}$ exceeds 200, and K = end fixity factor, L = actual length and r = radius of gyration.

Reference page 15 for general fitting and standard finish specifications.